

# CM108AH

Highly Integrated USB Audio Single Chip



## DESCRIPTION

The CM108AH is a highly integrated single-chip USB audio solution. All essential analog modules are embedded in the CM108AH, including dual DAC and earphone driver, ADC, microphone booster, PLL, regulator and USB transceiver modules. It is perfectly suited to USB headset, USB earphone or USB audio-interface box applications. As well, many features are programmable with jumper pins or by external EEPROM.

Audio adjustments are easily controlled via specific HID-compliant volume control pins. An external codec or audio DSP can be connected to the CM108AH via I2S pin for further processing.

## FEATURES

- Supports USB 2.0 full speed operation
- Compliant with USB audio device class specification 1.0
- Supports USB suspend/resume modes and remote wakeup with volume control pins
- Single 12MHz crystal input with on-chip PLL and embedded USB transceiver
- Jumper pin for speaker mode (playback only) or headset mode (playback plus recording)
- For headset mode, USB audio function topology has 2 input terminals, 2 output terminals, 1 mixer unit, 1 selector unit, and 3 feature units
- Jumper pin allows for mixer unit enable/disable when in headset mode

## BLOCK DIAGRAM

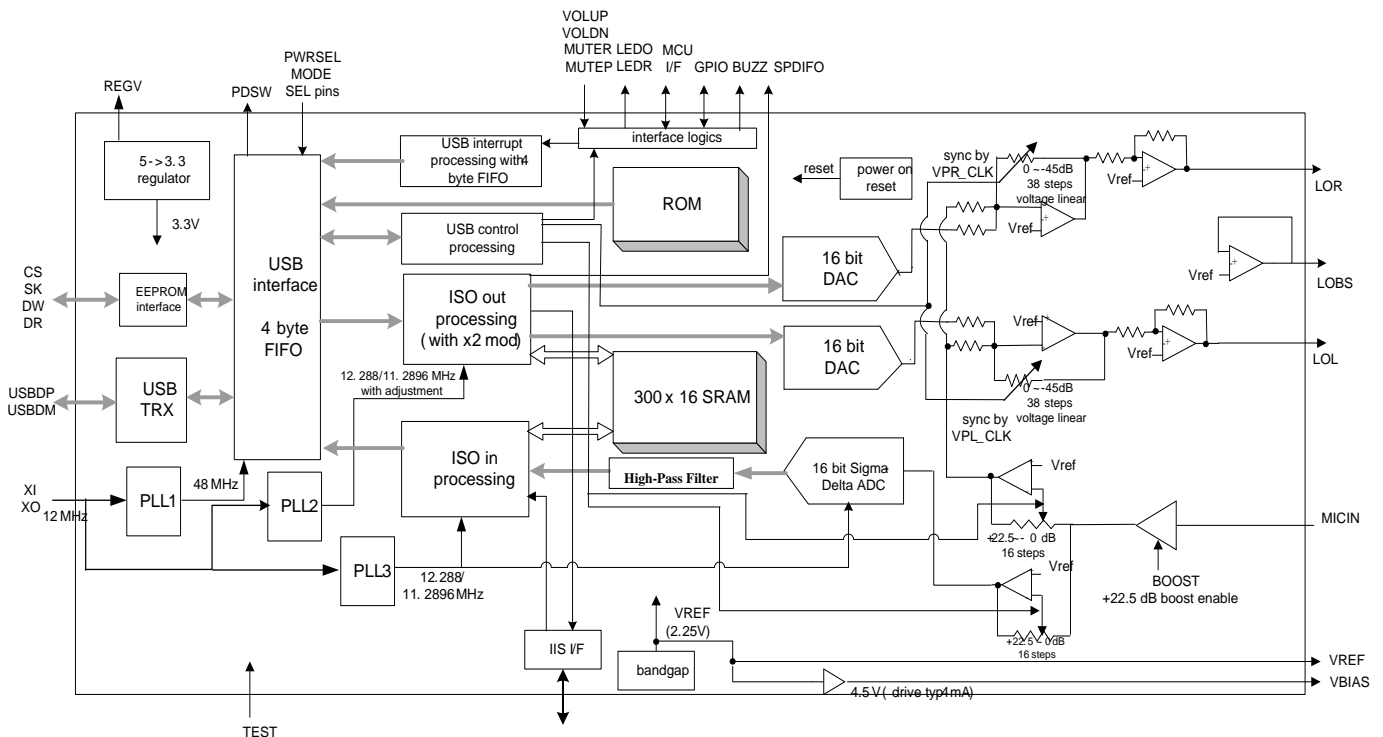

### TABLE OF CONTENTS

1	Description and Overview .....	3
2	Features .....	3
3	Pin Descriptions .....	5
3.1	Pin Assignment by Pin Number .....	5
3.2	Pin-Out Diagram.....	5
3.3	Pin Signal Descriptions .....	6
4	I <sup>2</sup> S Interface .....	8
5	Block Diagram .....	9
6	Ordering Information.....	10
7	Function Description .....	11
7.1	USB Interface .....	11
7.1.1	Device Descriptors .....	11
7.1.2	Configuration Descriptors .....	12
7.1.3	Content Format for EEPROM (93C46).....	13
7.1.4	USB Audio Topology Diagram .....	14
7.2	Jumper Pins and Mode Setting:.....	15
7.3	HID Feature .....	16
7.3.1	What's HID? .....	16
7.3.2	HID Descriptors.....	17
7.4	Internal Registers .....	18
8	Electrical Characteristics.....	21
8.1	Absolute Maximum Rating .....	21
8.2	Operation Conditions.....	21
8.3	Electrical Parameters .....	22
9	Audio Quality Graphs.....	23
9.1	Line Out Frequency Response @ 48KHz Sample Rate (10K Ohm Loading) .....	23
9.2	Line Out THD+N @ 48KHz sample rate (10K Ohm Loading).....	23
9.3	Microphone Input Frequency Response @ 48KHz Sample Rate.....	24
9.4	Microphone Input THD+N @ 48KHz Sample Rate .....	24
	Reference .....	25

### 1 Description and Overview

The CM108AH is a highly integrated single-chip USB audio solution. All essential analog modules are embedded in the CM108AH, including dual DAC and earphone driver, ADC, microphone booster, PLL, regulator and USB transceiver modules. It is perfectly suited to USB headset, USB earphone or USB audio-interface box applications. As well, many features are programmable with jumper pins or by external EEPROM.

Audio adjustments are easily controlled via specific HID-compliant volume control pins. An external codec or audio DSP can be connected to the CM108AH via I2S pin for further processing. Plus, 3 GPIO pins can be accessed with customer application software for additional value-adding applications.

### 2 Features

- Supports USB 2.0 full speed operation
- Compliant with USB audio device class specification 1.0
- Supports USB suspend/resume modes and remote wakeup with volume control pins
- Single 12MHz crystal input with on-chip PLL and embedded USB transceiver
- Jumper pin for speaker mode (playback only) or headset mode (playback plus recording)
- For headset mode, USB audio function topology has 2 input terminals, 2 output terminals, 1 mixer unit, 1 selector unit and 3 feature units
- Jumper pin allows for mixer unit enable/disable when in headset mode
- For speaker mode, the USB audio topology has 1 input terminal, 1 output terminal and 1 feature unit
- Supports one control endpoint, one isochroous OUT endpoint, one isochroous IN endpoint, and one interrupt IN endpoint
- Alternate zero bandwidth setting for releasing playback bandwidth on USB Bus when device is inactive
- Supports AES/EBU, IEC60958, S/PDIF consumer formats for stereo PCM data at S/PDIF output
- Volume up, volume down, and playback mute pins support USB HID for host control synchronization
- Record mute pin with LED indicator for record mute status
- External EEPROM interface for vendor-specific USB VID, PID and serial number
- EEPROM write function via vendor-specific request for mass production convenience
- Customized embedded VID, PID, product and manufacturer strings and volume settings are available
- 3 GPIO pins with read/write via HID interface
- Jumper pin to set the power mode (100mA or 500mA, Bus-powered or self-powered)
- Isochronous transfer uses adaptive mode with internal PLL for synchronization
- 48K/44.1KHz sampling rate for both playback and recording
- Soft mute function
- Embedded high-performance 16-bit audio DAC with earphone phone amplifier

# CM108AH

Highly Integrated USB Audio Single Chip

---



- Embedded 16-bit ADC input with microphone boost
- Embedded power-on reset block
- Embedded 5V to 3.3V regulator for single external 5V operation
- 48-pin LQFP package

### 3 Pin Descriptions

#### 3.1 Pin Assignment by Pin Number

Pin #	Signal Name	Pin #	Signal Name	Pin #	Signal Name	Pin #	Signal Name
1	SPDIFO	13	GPIO3	25	VBIAS	37	REGV
2	DR	14	DVSS1	26	VREF	38	MSEL
3	DW	15	GPIO4	27	MICIN	39	VOLUP
4	SK	16	SDIN	28	N.C.	40	PDSW
5	CS	17	ADSCLS	29	AVDD1	41	USBDP
6	MUTER	18	MUTEP	30	LOL	42	USBDM
7	PWRSEL	19	ADLRCK	31	LOBS	43	GPIO1
8	XI	20	ADMCLK	32	LOR	44	SDOUT
9	XO	21	LEDR	33	AVSS2	45	DAMCLK
10	MODE	22	ADSEL	34	AVDD2	46	DALRCK
11	N.C.	23	TEST	35	DVDD	47	DASCLK
12	LEDO	24	AVSS1	36	DVSS2	48	VOLDN

#### 3.2 Pin-Out Diagram

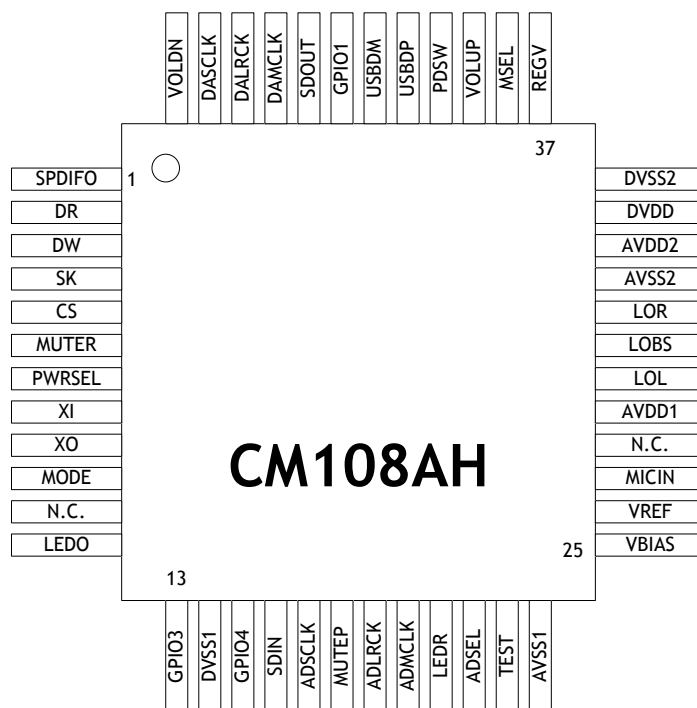

Pin Assignments (top view)

### 3.3 Pin Signal Descriptions

Pin #	Symbol	Type	Description
1	SPDIFO	DO, 8mA, SR	SPDIF output
2	DR	DIO, 8mA, PD, 5VT	EEPROM interface data read from EEPROM
3	DW	DO, 4mA, SR	EEPROM interface data write to EEPROM
4	SK	DO, 4mA, SR	EEPROM interface clock
5	CS	DO, 4mA, SR	EEPROM interface chip select
6	MUTER	DI, ST, PU	Mute recording (edge trigger with de-bouncing)
7	PWRSEL	DI, ST	Chip power select pin, worked by MODE Pin Speaker mode - H: 100mA self-powered L: 500mA Bus-powered Headset mode - H: 100mA Bus-powered, L: 500mA Bus-powered (H: push up to 3.3V, L: push down to ground)
8	XI	DI	Input pin for 12MHz oscillator
9	XO	DO	Output pin for 12MHz oscillator
10	MODE	DI, ST	Operating mode selection H: speaker mode - playback only L: headset mode - playback & recording (H: push up to 3.3V, L: pull down to ground)
11	N.C.		
12	LEDO	DO, SR, 8mA	LED operation light: output H for power on, toggling for data transmit
13	GPIO3	DIO, 8mA, PD, 5VT	GPIO pin
14	DVSS1	P	Digital ground
15	GPIO4	DIO, 8mA, PD, 5VT	GPIO pin
16	SDIN	DIO, 8mA, PD, 5VT	ADC I2S data input
17	ADSCCLK	DIO, 4mA, SR	ADC I2S serial clock
18	MUTEP	DI, ST, PU	Mute playback (edge trigger with de-bouncing)
19	ADLRCK	DO, 4mA, SR	ADC I2S left/right clock
20	ADMCLK	DIO, 4mA, SR	11.2896MHz output for 44.1KHz sampled data and 12.288MHz output for 48KHz sampled data
21	LEDR	DO, SR, 8mA	LED for mute recording indicator, output H when recording is muted
22	ADSEL	DI, ST, PD	ADC input source select pin H: use external (via I2S) ADC L: use internal ADC (H: push up to 3.3V, L: push down to ground)
23	TEST	DI, ST, PD	Test mode select pin, H: test mode L: normal operation (H: push up to 3.3V, L: push down to ground)
24	AVSS1	P	Analog ground
25	VBIAS	AO	Microphone bias voltage supply (4.5V), with small driving capability
26	VREF	AO	Connecting to external decoupling capacitor for embedded bandgap circuit, 2.25V output
27	MICIN	AI	Microphone input
28	N.C.		
29	AVDD1	P	5V analog power for analog circuit
30	LOL	AO	Line out: left channel

# CM108AH

Highly Integrated USB Audio Single Chip



31	LOBS	AO	DC 2.25V output for line out bias
32	LOR	AO	Line out: right channel
33	AVSS2	P	Analog ground
34	AVDD2	P	5V power supply for analog circuit
35	DVDD	P	5V power supply for internal regulator
36	DVSS2	P	Digital ground
37	REGV	AO	3.3V reference output for internal 5V to 3.3V regulator
38	MSEL	DI, ST	Mixer enable select, worked by MODE pin, H: with mixer/AA-path enabled (with default mute) L: without mixer/AA-path disabled (H: push up to 3.3V, L: push down to ground) USB descriptors will also be changed accordingly
39	VOLUP	DI, ST, PU	Volume up (edge trigger with de-bouncing)
40	PDSW	DO, 4mA, OD	Power down switch control signal (for PMOS polarity) 0: normal operation 1: power down mode (suspend mode)
41	USBDP	AIO	USB Data D+
42	USBDM	AIO	USB Data D-
43	GPIO1	DIO, 8mA, PD, 5VT	GPIO pin
44	SDOUT	DO, 4mA, SR	DAC I2S data output
45	DAMCLK	DO, 4mA, SR	11.2896 MHz output for 44.1KHz sampled data and 12.288 MHz output for 48KHz sampled data
46	DALRCK	DO, 4mA, SR	DAC I2S left/right clock
47	DASCLK	DO, 4mA, SR	DAC I2S serial clock
48	VOLDN	DI, ST, PU	Volume down (edge trigger with de-bouncing)

**NoteU:** DI / DO / DIO - Digital Input / Output / Bi-Directional Pad

AI / AO / AIO - Analog Input / Output / Bi-Directional Pad

SR - Slew Rate Control

ST - Schmitt Trigger

PD / PU - Pull Down / Pull Up

5VT - 5 Volt Tolerant (3.3V Pad)

OD - Open Drain

### 4 I<sup>2</sup>S Interface

The CM108AH provides an IP<sup>2</sup>S interface for both playback and recording. External ADC, DAC, or DSP can be added to provide additional functions within the USB audio system. The CM108AH sends out master clock (fixed at x256), LRCK (fixed at x64), and data clock data. Therefore, external ADCs, DACs, or DSPs should be set to slave mode.

The left channel of the CM108AH's IP<sup>2</sup>S bus is used for mono recording. Both IP<sup>2</sup>S buses use a 5V tolerant pad in order to easily interface with 5V or 3.3V devices. Playback data is simultaneously sent to both the DAC and IP<sup>2</sup>S bus. The recording source (ADC or IP<sup>2</sup>S bus) can be selected by ADSEL jumper pin.

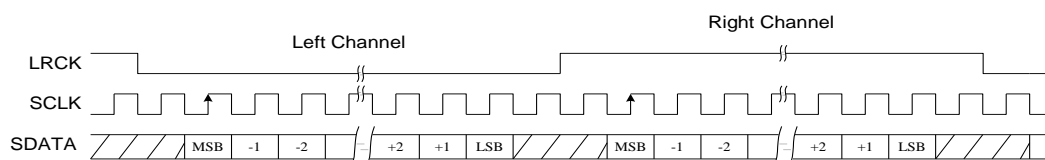



# CM108AH

Highly Integrated USB Audio Single Chip



## 5 Block Diagram

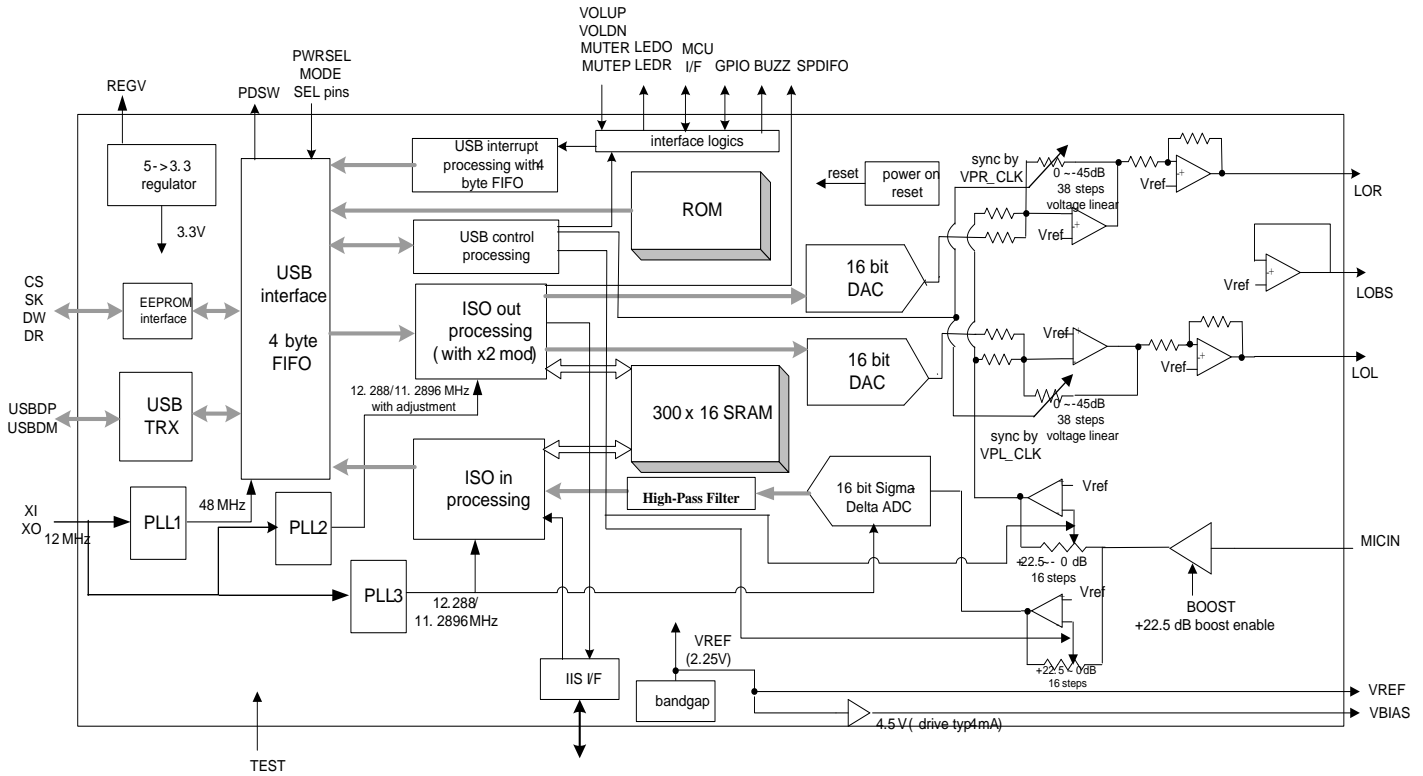

CM108AH Block Diagram

# CM108AH

Highly Integrated USB Audio Single Chip



## 6 Ordering Information

Model No.	Package	Operating Ambient Temperature	Supply Range
CM108AH	48-pin LQFP, 7mm × 7mm × 1.4mm (plastic)	-15°C to +70°C	DVdd = 5V, AVdd = 5V

Note: Outline Dimensions are shown in inches and millimeters

48-Lead Thin Plastic Quad Flatpack (LQFP)

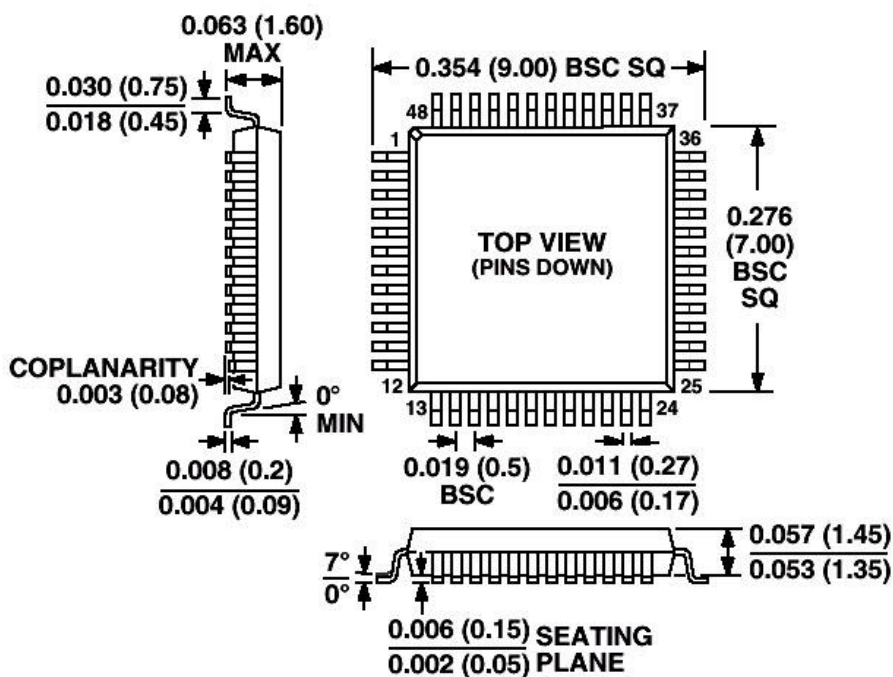

CM108AH Ordering Information

## 7 Function Description

### 7.1 USB Interface

The CM108AH integrates USB transceiver, PLL and regulator modules, meaning only a few passive components are necessary for USB interface connection. Default USB descriptors are embedded in the CM108AH, so no additional design effort is needed for generic USB operation. For custom orders, customers can attach a 93C46 EEPROM to override the embedded VID, PID, product and manufacturer strings, and serial number for each set. The CM108AH automatically detects the 93C46, and the overwrite function is performed at start up.

#### 7.1.1 Device Descriptors

Offset	Field	Size	Value (Hex)	Description
0	bLength	1	12	Total: 18 bytes
1	bDescriptorType	1	01	Device descriptor
2	bcdUSB	2	0110	USB 1.1-compliant
4	bDeviceClass	1	00	
5	bDeviceSubClass	1	00	
6	bDeviceProtocol	1	00	
7	bMaxPacketSize0	1	40	Endpoint zero size = 64 bytes
8	idVendor	2	0d8c	Vendor ID
10	idProduct	2	0139	Product ID programmable by MSEL and MODE pin
12	bcdDevice	2	0100	Device compliant with Audio Device class specification version 1.0
14	iManufacturer	1	01	String descriptor index describes manufacturer
15	iProduct	1	02	String descriptor index describes product
16	iSerialNumber	1	03	String descriptor index displays device serial no.
17	bNumConfigurations	1	01	Configuration number = 1

### 7.1.2 Configuration Descriptors

Offset	Field	Size	Value (Hex)	Description
0	bLength	1	09	Total: 9 bytes
1	bDescriptorType	1	02	Configuration descriptor
2	wTotalLength	2		Total length of data returned for this configuration, programmable by MSEL and MODE pin
4	bNumInterfaces	1	04 or 03	Number of interfaces supported by this configuration, changed by MODE pin: EP0: control interface EP1: ISO-OUT interface EP2: ISO-IN interface (optional) EP3: INT-IN (HID) interface
5	bConfigurationValue	1	01	
6	iConfiguration	1	00	
7	bmAttributes	1	A0 or E0	Programmable by PWRSEL
8	bMaxPower	2	32 or FA	Maximum power consumption of the USB, programmable by MODE and PWRSEL pins

### 7.1.3 Content Format for EEPROM (93C46)

Addr (Dec)	Addr (Hex)	Description
0	0x00	Magic Word 0x670X where X = bit 4, 3, 2, 1 bit 3, value within address 0x2A,0x2B is valid 1: valid 0: invalid bit 2, manufacture string enable 1: enable(default) 0: disable bit 1, serial number enable control 1: enable 0: disable(default) bit 0, product string enable control 1: enable(default) 0: disable
1	0x01	VID 2-byte
2	0x02	PID 2-byte
3	0x03	Serial number length (low byte)   Serial number first byte (high byte)
4 ~ 9	0x04 ~ 0x09	Serial number: 12 bytes
10	0x0A	Product string length (low byte)   Product string first byte (high byte)
11 ~ 25	0x0B ~ 0x19	Product string: 30 bytes (default: USB PnP sound device)
26	0x1A	Manufacturer string length (low byte)   Manufacturer string first byte <sup>t</sup> (high byte)
27 ~ 41	0x1B ~ 0x29	Manufacturer string: 30 bytes (default: C-Media Electronics Inc.)
42	0x2A	bit 15 - 8 DAC initial volume (7-bit) max: 0x02 min: 0x4a bit 7 - 0 ADC initial volume (5-bit) max: 0x00 min: 0x78
43	0x2B	bit 15 - bit 9 <reserved> bit 8 Shutdown DAC analog - 1: shutdown, 0: active (default) bit 7 Total power control - 1: enable, 0: disable (default) bit 6 Reserved, should be 0 bit 5 MIC high pass filter - 1: enable (default), 0: disable bit 4 ADC synchronization mode - 1: enable, 0: disable (default) bit 3 MIC BOOST - 1: enable (default), 0: disable bit 2 DAC output terminal property set to SPK or HP 1: Headset, 0: Speaker (default) bit 1 HID - 1: enable (default), 0: disable bit 0 Remote wakeup enable/disable 1: enable, 0: disable (default)
44 ~ END	0x2C ~ END	<reserved>

### 7.1.4 USB Audio Topology Diagram

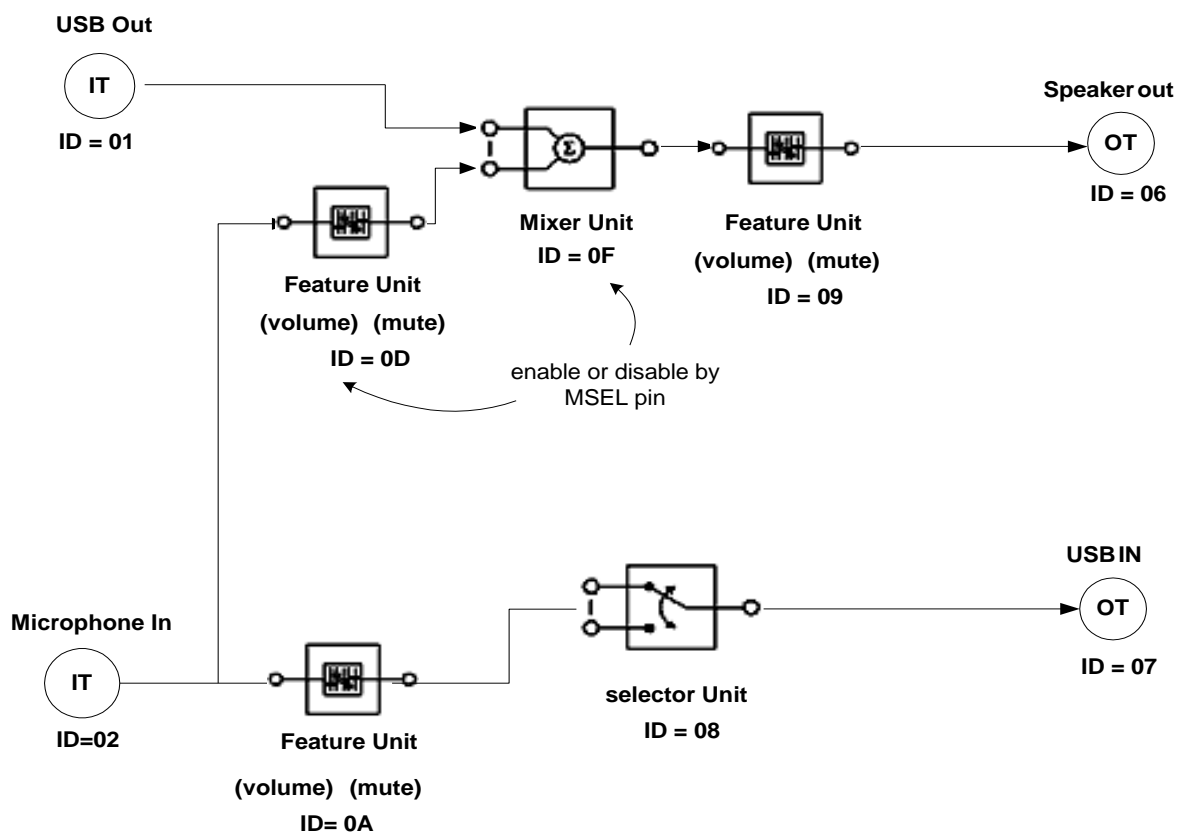

### 7.2 Jumper Pins and Mode Setting:

The CM108AH can be configured via several jumper pins. These jumper pin settings affect both USB descriptors and USB audio topology.

#### 7.2.1 MODE Pin and MSEL Pin

If the MODE pin is pushed up to 3.3V (speaker mode), a playback-only function is activated and no recording function is declared to the host. At this setting, the MSEL pin is ignored and only one input terminal, one output terminal and one feature unit is declared in the USB audio topology.

If the MODE pin is pulled low (headset mode), a full-duplex playback and recording function is reported to the host. The MSEL pin setting activates one mixer unit and one feature unit.

- When MSEL = 1, the mixer is enabled (AA-path enabled), but with default mute setting
- When MSEL = 0, the mixer is disabled (AA-path disabled)

The above USB audio topology (7.1.4) is an example of headset mode with enabled mixer.

#### 7.2.2 MODE Pin and PWRSEL Pin

The PWRSEL pin affects the power configuration of the CM108AH. Together with the MODE pin, there are a total of 4 programmable combinations.

Combinations		MODE	
		3.3V	GND
PWRSEL	3.3V	Speaker mode: Playback only (100mA self-powered)	Headset mode: Playback and recording (100mA Bus-powered)
	GND	Speaker mode: Playback only (500mA Bus-powered)	Headset mode: Playback and recording (500mA Bus-powered)

USB Audio Topology Diagram

### 7.3 HID Feature

The CM108AH's HID feature allows users to set volume up, volume down, playback mute and recording mute button pins, and reports the changes to the host to synchronize host side settings. In addition, all CM108AH internal registers can be accessed via HID function call.

#### 7.3.1 What's HID?

USB protocols can configure devices at startup or when they are plugged in at run time. These devices are categorized into various device classes. Each device class defines the common behavior and protocols for devices that serve similar functions. The HID (Human Interface Device) class is one of the device classes.

The HID class consists primarily of devices that are used to control the operation of computer systems. Typical examples of HID class devices include:

- Keyboards and pointing devices: mice, trackballs and joysticks
- Front-panel controls: knobs, switches, buttons and sliders
- Controls that might be found on VCR remote controls, games or simulation devices: data gloves, throttles, and steering wheels
- Devices that may not require human interaction but provide data in a similar format to HID class devices: bar-code readers, thermometers or voltmeters



### 7.3.2 HID Descriptors

#### HID Interface Descriptor

Offset	Field	Size	Value (Hex)	Description
0	bLength	1	09	Size of this descriptor: 9 bytes
1	bDescriptorType	1	04	Interface descriptor type
2	bInterfaceNumber	1	03	Interface number: 3
3	bAlternateSetting	1	00	Alternate: 0
4	bNumEndpoints	1	01	Number of endpoints used by this interface: 1
5	bInterfaceClass	1	03	Interface class: HID
6	bInterfaceSubClass	1	00	Subclass: no
7	bInterfaceProtocol	1	00	Must be set to 0
8	iInterface	1	00	String descriptor index that describes this interface

#### HID Descriptor

Offset	Field	Size	Value (Hex)	Description
0	bLength	1	09	Total: 9 bytes
1	bDescriptorType	1	21	HID descriptor type
2	bcdHID	2	0100	HID class version 1.0
4	bCountryCode	1	00	
5	bNumDescriptors	1	01	
6	bDescriptorType	1	22	Report descriptor
7	wDescriptorLength	2	0030	Total size of the optional descriptor: 48 bytes

#### Interrupt IN Endpoint Descriptor

Offset	Field	Size	Value (Hex)	Description
0	bLength	1	07	Total: 7 bytes
1	bDescriptorType	1	05	Endpoint descriptor type
2	bEndpointAddress	1	83	In Endpoint Number = 3
3	bmAttributes	1	03	Interrupt endpoint type
4	wMaxPacketSize	2	0004	Maximum packet size: 4 bytes
6	Interval	1	2	2ms

### 7.4 Internal Registers

All of CM108AH's internal registers can be accessed via generic HID functional calls without the need to develop a kernel mode driver. In total, 4 bytes of data can be read or written from the HID. The input report is for read and the output report is for write. These internal registers are used to control GPIO pin, S/PDIF output and EEPROM data access.

#### HID\_IR0 (HID input report byte 0)

Offset: 0x00

Bits	Read/Write	Description	Default
7-6	R	00: HID_IR1 is used as GPI, 10: values written to HID_IR0-3 are also mapped to EPROM_DATA0-1 and EEPROM_CTRL Others: reserved	0x0
5-4	R	Reserved	0x0
3	R	0: no activity on record/mute button 1: record/mute button pressed then released	0x0
2	R	0: no activity on playback/mute button 1: playback/mute button pressed then released	0x0
1	R	0: volume-down button released 1: volume-down button pressed	0x0
0	R	0: volume-up button released 1: volume-up button pressed	0x0

#### HID\_IR1 (HID input report byte 1)

Offset: 0x01

Bits	Read/Write	Description	Default
7-0	R	When HID_IR0[7:6] == 2'b00: HID_IR1[3:0] is the input from GPIO4 ~ GPIO1 in input mode When HID_OR0[7] == 1'b1: mapped from EEPROM_DATA0	0x00

#### HID\_IR2 (HID input report byte 2)

Offset: 0x02

Bits	Read/Write	Description	Default
7-0	R	When HID_OR0[7] == 1'b1: mapped from EEPROM_DATA1	0x00

### HID\_IR3 (HID input report byte 3)

Offset: 0x03

Bits	Read/Write	Description	Default
7-0	R	When HID_OR0[7] == 1'b1: mapped from EEPROM_CTRL	0x00

### HID\_OR0 (HID output report byte 0)

Offset: 0x04

Bits	Read/Write	Description	Default
7-6	R / W	0: HID_OR1-2 are used for GPO; HID_OR0, 3 are used for SPDIF 1: reserved 2: values written to HID_OR0-3 are also mapped to EEPROM_DATA0-1, EEPROM_CTRL (See Note) 3: reserved	0x0
5	R / W	Reserved	0x0
4	R / W	When HID_OR0[7] == 1'b0: valid bit in SPDIF frame When HID_OR0[7] == 1'b1: reserved	0x0
3-0	R / W	When HID_OR0[7] == 1'b0: first nibble of SPDIF status channel When HID_OR0[7] == 1'b1: reserved	0x0

Note 1: When EEPROM access is done, HID interrupt will occur. USB host can get the result from interrupt pipe (endpoint 3).

Note 2: HID\_OR0 is used for SPDIF when SPDIF\_CONFIG[5] == 1'b0

### HID\_OR1 (HID output report byte 1)

Offset: 0x05

Bits	Read/Write	Description	Default
7-0	R / W	When HID_OR0[7:6] == 2'b00: HID_OR1[3:0] is the output to GPIO4 ~ GPIO1 in output mode 0: GPO drives L 1: GPO drives H When HID_OR0[7:6] == 2'b01: reserved When HID_OR0[7:6] == 2'b1x: mapped to EEPROM_DATA0	0x00

### HID\_OR2 (HID output report byte 2)

Offset: 0x06

Bits	Read/Write	Description	Default
7-0	R / W	When HID_OR0[7:6] == 2'b00: HID_OR2[3:0] is the mode setting for GPIO4 ~ GPIO1 0: set GPIO to input mode 1: set GPIO to output mode When HID_OR0[7:6] == 2'b01: reserved When HID_OR0[7:6] == 2'b1x: mapped to EEPROM_DATA1	0x00

### HID\_OR3 (HID output report byte 3)

Offset: 0x07

Bits	Read/Write	Description	Default
7-0	R / W	When HID_OR0[7] == 1'b0: category byte of SPDIF status channel When HID_OR0[7] == 1'b1: mapped to EEPROM_CTRL	0x00

Note: HID\_OR3 is used for SPDIF when SPDIF\_CONFIG[5] == 1'b0

### 8 Electrical Characteristics

#### 8.1 Absolute Maximum Rating

Symbol	Parameters	Value	Unit
Dvmin	Min. digital supply voltage	- 0.3	V
Dvmax	Max. digital supply voltage	+ 6	V
Avmin	Min. analog supply voltage	- 0.3	V
Avmax	Max. analog supply voltage	+ 6	V
Dvinout	Voltage on any digital input or output pin	-0.3 to +5.5	V
Avinout	Voltage on any analog input or output pin	-0.3 to +5.5	V
TBstgB	Storage temperature range	-40 to +125	POPC
ESD (HBM)	ESD human body mode	4000	V
ESD (MM)	ESD machine mode	200	V
Latch Up	JEDEC standard no.78, Mar. 1997	200	mA

#### 8.2 Operation Conditions

Operation conditions				
	Min	Typ	Max	Unit
Analog supply voltage	4.5	5.0	5.5	V
Digital supply voltage	4.5	5.0	5.5	V
Total power consumption	-	35		mA
Suspend-mode power consumption	-	500		uA
Operating ambient temp.	-15	-	70	PoPC

### 8.3 Electrical Parameters

	Min.	Typ.	Max.	Unit
<b>DAC (10K Ohm Loading)</b>				
Resolution	-	16	-	Bits
THD + N (-3dBr)@1KHz	-	-74.29	-	dB
SNR	-	93.6	-	dB
Silent SNR	-	98.2	-	dB
Dynamic range	-	93.8	-	dB
Frequency response 48KHz	20	-	20K	Hz
Frequency response 44.1KHz	20	-	20K	Hz
Full Scale Output voltage (rms)	-	1.25	-	Vrms
<b>DAC (32 Ohm loading)</b>				
Resolution	-	16	-	Bits
THD + N (-3dBr)@1KHz	-	-71.1	-	dB
SNR	-	93.7	-	dB
Silent SNR	-	98.2	-	dB
Dynamic range	-	93.8	-	dB
Frequency response 48KHz	20	-	20K	Hz
Frequency response 44.1KHz	20	-	20K	Hz
Full Scale Output voltage (rms)	-	1.20	-	Vrms
<b>Output Volume Control</b>				
Volume control level	-28.3	-	0	dB
Volume control step	-	38	-	Steps
<b>ADC</b>				
Resolution	-	16	-	bit
THD + N (-3dBr) @1KHz	-	-76.1	-	dB
SNR	-	83.1	-	dB
Dynamic range	-	81.6	-	dB
Frequency response 48KHz	20	-	19.2K	Hz
Frequency response 44.1KHz	20	-	17.6K	Hz
Input range	0	-	2.88	Vpp
<b>Microphone Input</b>				
Boost gain	-	+22.5	-	dB
Gain adjustment range	0	-	23.9	dB
Gain adjustment steps	-	16	-	Steps
Mixer gain adjustment	0	-	23.9	dB
Mixer gain adjustment steps	-	16	-	Steps

### 9 Audio Quality Graphs

#### 9.1 Line Out Frequency Response @ 48KHz Sample Rate (10K Ohm Loading)

Audio Precision

09/26/08 14:33:51

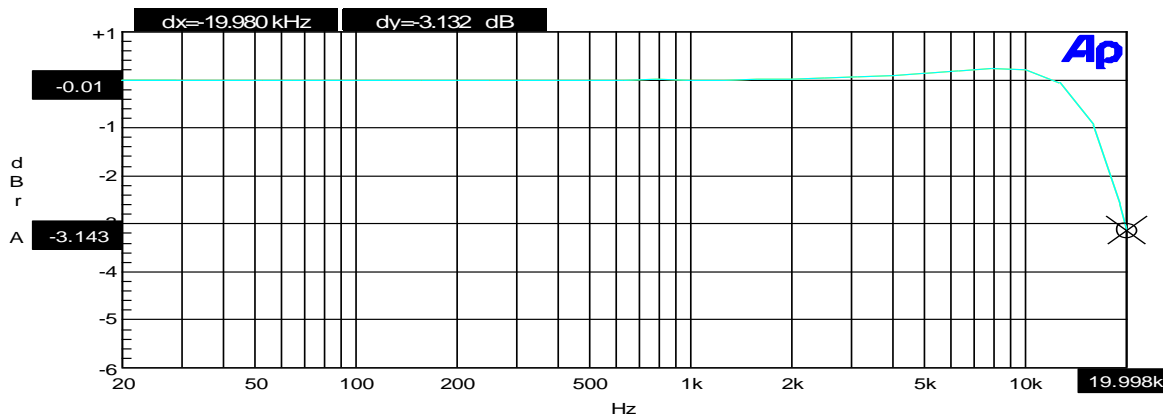

Sweep	Trace	Color	Line Style	Thick	Data	Axis	Comment
1	1	Cyan	Solid	1	Fasttest.Ch.1 Ampl!Normalize	Left	
1	2	Yellow	Solid	1	Fasttest.Ch.2 Ampl!Normalize	Left	

Vista-Frequency Response-M48k.at27

#### 9.2 Line Out THD+N @ 48KHz sample rate (10K Ohm Loading)

Audio Precision

09/26/08 14:27:07

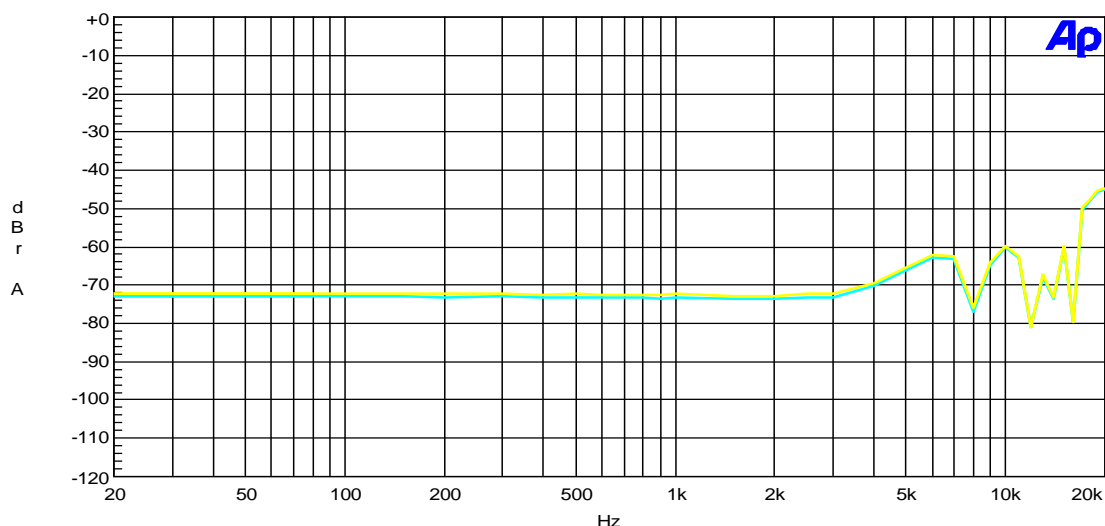

Sweep	Trace	Color	Line Style	Thick	Data	Axis	Comment
1	1	Cyan	Solid	2	Anlr.THd+N Ampl	Left	
1	2	Yellow	Solid	2	Anlr.THd+N Ampl	Left	

Vista-D-A THD+N.at27

### 9.3 Microphone Input Frequency Response @ 48KHz Sample Rate

Audio Precision      A-D FREQUENCY RESPONSE      09/26/08 14:52:45

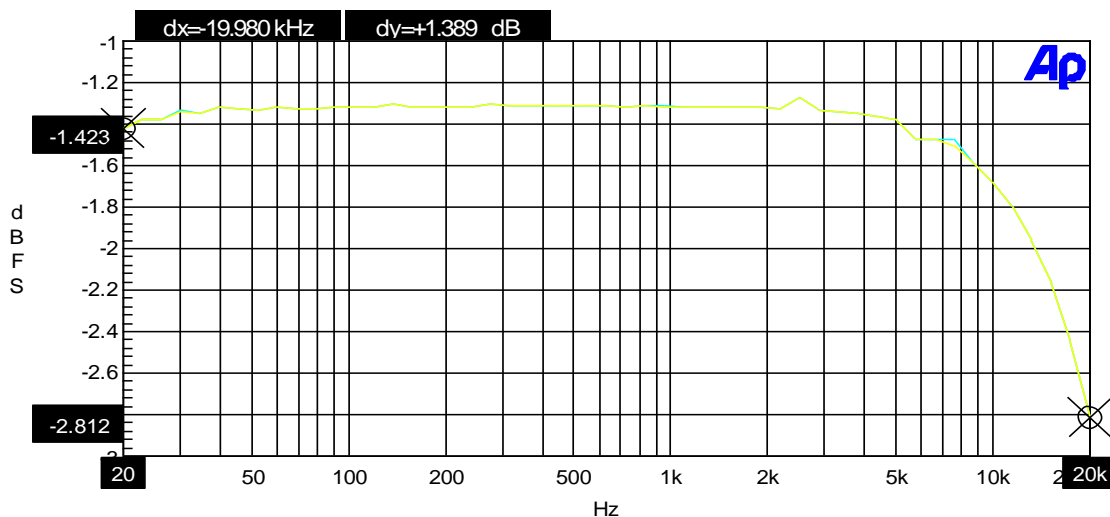

Sweep	Trace	Color	Line Style	Thick	Data	Axis	Comment	Cursor1
1	1	Yellow	Solid	1	DSP Anlr.Level A	Left		*-2.812 dBFS
1	2	Cyan	Solid	1	DSP Anlr.Level B	Left		-2.812 dBFS

Vista-A-D Frequency Response.at2c

### 9.4 Microphone Input THD+N @ 48KHz Sample Rate

Audio Precision      A-D THD+N vs FREQUENCY      09/26/08 14:51:13

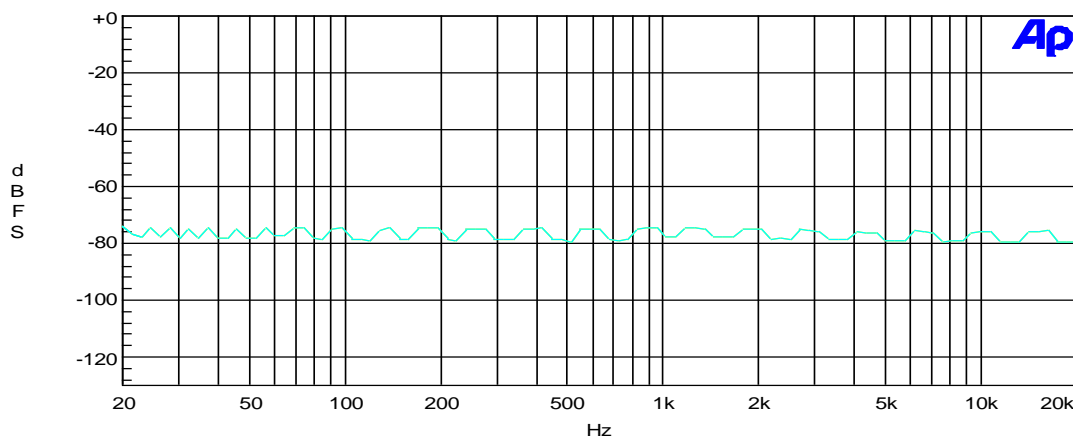

Sweep	Trace	Color	Line Style	Thick	Data	Axis	Comment
1	1	Yellow	Solid	1	DSP Anlr.THd+N Ampl A	Left	
1	2	Cyan	Solid	1	DSP Anlr.THd+N Ampl B	Left	

Vista-A-D THD+N.at2c



# CM108AH

Highly Integrated USB Audio Single Chip

---



## Reference

- USB specification 1.1 and 2.0-compliant
- USB audio device class specification 1.0-compliant
- USB human interface device class specification 1.11-compliant

— End of Datasheet —

# CM108AH

Highly Integrated USB Audio Single Chip

---



C-MEDIA ELECTRONICS INC.

6F., 100, Sec. 4, Civil Boulevard, Taipei, Taiwan 106 R.O.C.

TEL : 886-2-8773-1100

FAX : 886-2-8773-2211

E-MAIL : [sales@cmedia.com.tw](mailto:sales@cmedia.com.tw)

**Disclaimer:**

Information furnished by C-Media Electronics Inc. is believed to be accurate and reliable. However, no responsibility is assumed by C-Media Electronics Inc. for its use, nor for any infringements of patents or other rights of third parties that may result from its use. Specifications subject to change without notice. No license is granted by implication or otherwise under any patent or patent rights of C-Media. Trademark and registered trademark are the property of their respective owners.